

GRAMERCY LOW TABLE

MAURO LIPPARINI



MisuraEmme

Harmonious design and soft lines with clear influence drawn from the world of sculpture, coming together to create a piece with absolute aesthetic value. Different dimensions and materials make for a sophisticated item for the living room. The legs, a triptych easel, follow the same drawing of the table.

TYPE / SMALL TABLES

TECHNICAL DESCRIPTION

*Series of table with base hand in crafted. Various are the modification of the tipology, dimensions and finishing in a game of combination: wood and varnish or all lacquer tone on tone or in contrast; the legs, a triptych easel, follow the same drawing of **Gramercy** table.*

The plan is supported by spacers in brushed steel.

Finishes wooden top with shaped undertop:

- veneered top with undertop in matt lacquered
- veneered top with undertop in glossy lacquered
- top and undertop in matt lacquered
- top and undertop in glossy lacquered
- top in marble th. 20mm (6/8").

The high and low Sidetable is also available with top in transparent glass th.8mm (3/8")



DESIGNER

MAURO LIPPARINI

Mauro Lipparini earned a degree in Architecture in 1980 from Università degli Studi of Florence, where he also worked as a professor. He won the international design contests Young & Designer Milan (1987) and International Du Pont Award Köln (Germany, 1988 and 1989). Lipparini's intense activity in the field of industrial design covers office and home furniture, the textile industry and other products created for many companies in Europe and Japan. In architecture and interior design, Lipparini has concentrated mainly on private and public housing, on showrooms, retail sales outlets and exposition installations. Furthermore, Lipparini also designs and realizes advanced corporate identity image systems that range from graphics to editorial services to production. Lipparini's style is based on the essential shapes and the clear and decisive lines that are characteristic of natural minimalism. His creations are imbued with a joyful spirit and with an elating sense of aesthetic pleasure and creativity. Thanks to his free use of color, organic weave patterns and original visual ideas, Lipparini amplifies the palette of minimalism, conveying the spontaneity and power of this aesthetic style and projecting it towards a new era of great maturity and wellbeing.



MisuraEmme

TOP FINISHINGS

MATT LACQUERED



01 Gesso 8B Caolino 9G Ostrica 6B Grigio Pietra 14 Nero 02 Talco 9F Sand 4G Argilla



8C Cappuccino 5B Grigio Lava 72 Sabbia 8A Beige 9T Toffee 93 Melange 13 Sepia 12 Vinaccia



09 Wengè 81 Fuoco 94 Marsala 95 Ruggine 8S Giallo 9B Senape 98 Oliva 9H Petrolio



9E Deep Blu

HIGH GLOSS LACQUERED



L01 Gesso L8B Caolino L9G Ostrica L6B Grigio Pietra L14 Nero L02 Talco L9F Sand L4G Argilla



L8C Cappuccino L5B Grigio Lava L72 Sabbia L8A Beige L9T Toffee L93 Melange L13 Sepia L12 Vinaccia



L09 Wengè L81 Fuoco L94 Marsala L95 Ruggine L8S Giallo L9B Senape L98 Oliva L9H Petrolio



L9E Deep
Blu

TRANSPARENT GLASS

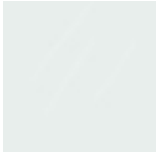

V00 Extra
light



V05 Fumé



V01 Bronzo

MARBLES

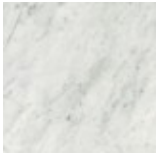

BC Bianco
Carrara
natural matt



CA Calacatta
Oro natural
matt

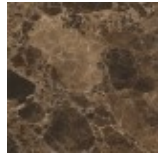

EM
Emperador
natural matt



TV
Travertino
natural matt

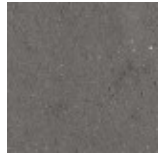

BA Basaltite
natural matt

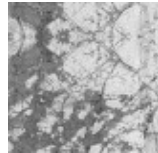

IG Invisible
Grey natural
matt



GT Grey
Stone
natural
glossy



MR
Marquinia
natural
glossy

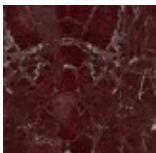

RL Rosso
Lepanto
natural
glossy



OR Orobico
natural
glossy

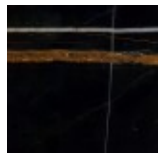

SR Sahara
Noir glossy
polyester

MATT VENEERS



50 Rovere
cenere

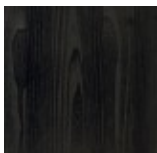

51 Black oak

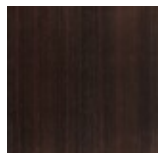

66 Tobacco

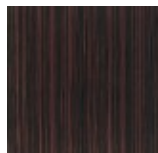

62 Ebony

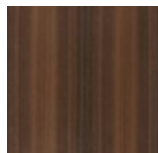

54
Eucalyptus

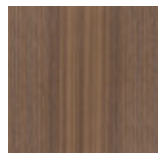

67 Noce
Canaletto

UNDERTOP FINISHINGS

MATT LACQUERED



01 Gesso 8B Caolino 9G Ostrica 6B Grigio Pietra 14 Nero 02 Talco 9F Sand 4G Argilla



8C Cappuccino 5B Grigio Lava 72 Sabbia 8A Beige 9T Toffee 93 Melange 13 Sepia 12 Vinaccia



09 Wengè 81 Fuoco 94 Marsala 95 Ruggine 8S Giallo 9B Senape 98 Oliva 9H Petrolio



9E Deep Blu

HIGH GLOSS LACQUERED



L01 Gesso L8B Caolino L9G Ostrica L6B Grigio Pietra L14 Nero L02 Talco L9F Sand L4G Argilla



L8C Cappuccino L5B Grigio Lava L72 Sabbia L8A Beige L9T Toffee L93 Melange L13 Sepia L12 Vinaccia



L09 Wengè L81 Fuoco L94 Marsala L95 Ruggine L8S Giallo L9B Senape L98 Oliva L9H Petrolio



L9E Deep
Blu

BASE FINISHINGS

MATT VENEERS



50 Rovere
cenere

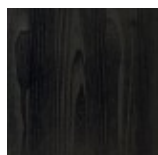

51 Black oak

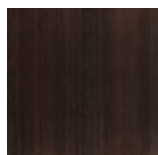

66 Tobacco

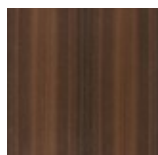

54
Eucalyptus

DIMENSIONS

Small table Ø 380 mm with lacquered top

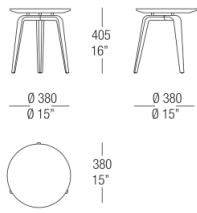

Small table Ø 380 mm with wood top

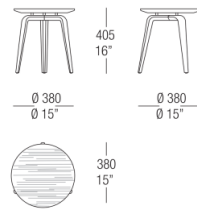

Small table Ø 380 mm with glass top

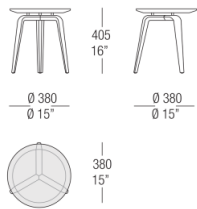

Small table Ø 380 mm with marble top

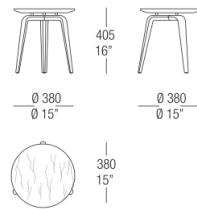

Small table Ø 550 mm with lacquered top

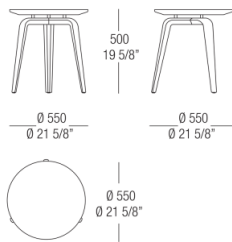

Small table Ø 550 mm with wood top

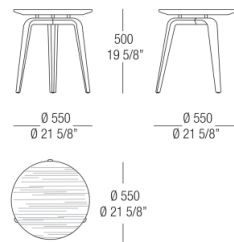

Small table Ø 550 mm with glass top

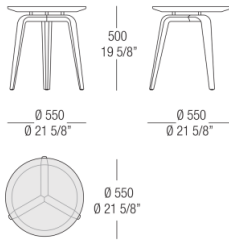

Small table Ø 550 mm with marble top

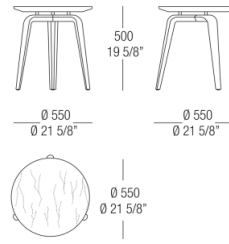

Small table Ø 1250 mm with lacquered top

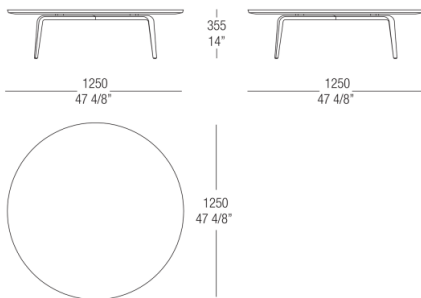

Small table Ø 1250 mm with wood top

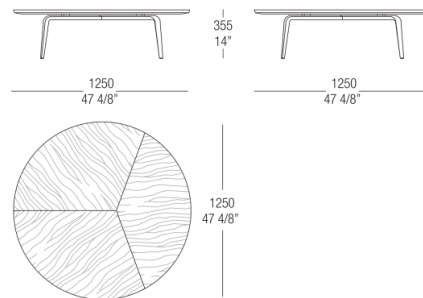

Small table Ø 1250 mm with marble top

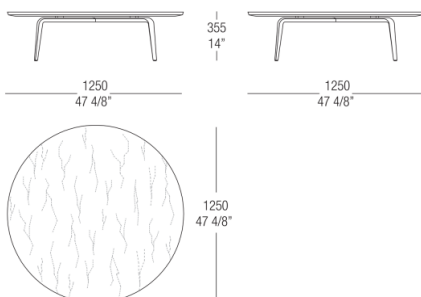

Small table W. 1200 mm with lacquered top

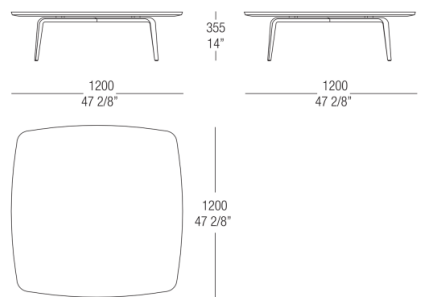

Small table W. 1200 mm with wood top

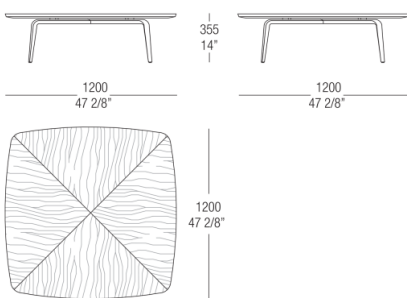

Small table W. 1200 mm with marble top

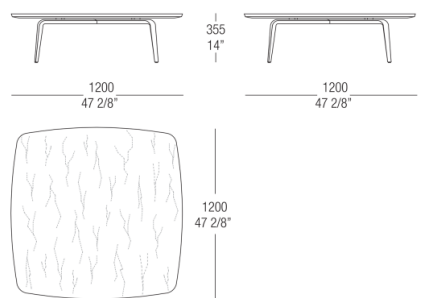

Small table W. 1700 mm with lacquered top

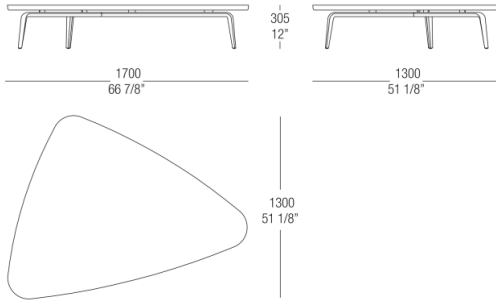

Small table W. 1700 with wood top

